

# Detachable gripper

## For all excavators in the 2–30 tonne weight classes

The gripper cassette simply hooks onto the Q-Safe-D quick hitch and is then locked in place and the hydraulics connected in a single action. The gripper is angled at 15 degrees to the plane of rotation, giving a longer reach.

The gripper cassette is locked and the hydraulics connected in one action using a 32 mm open-ended spanner. This allows the cassette to be attached or detached in less than a minute.

Engcon's detachable gripper cassette is also retrofittable.



### GR60

For excavators in the 12–19 tonne weight classes. Updated gripper arms for easier handling of objects with diameters from 25 to 800 mm. A developed function for synchronised movement of the gripper arms is included as standard.

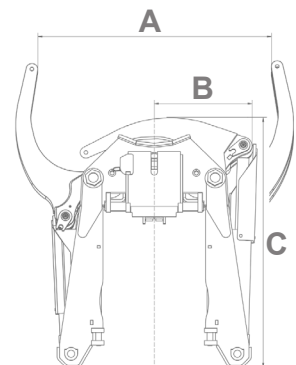
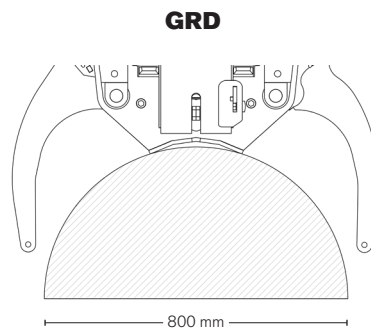
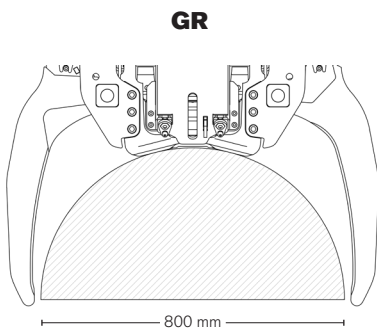

## Specifications

Model	GRD40	GRD45	GRD60	GRD70	GR60
Grab width A: (mm)	430	610	820	950	820
Width B: (mm)	220	270	355	410	389
Length C: (mm)	540	720	870	900	850
Clamping force (tip - tip) at 21MPa: (kg)	1 200	1 500	2 200	2 200	1 850
Max load: (kg)	1 000	1 500	2 000	2 000	2 000
Weight: (kg)	45	99	143	158	160
Max hydraulic pressure: (MPa)	22	22	22	22	22
Quick hitch standard:	S40	S45	S60	S70	S60

## CHANGE THE WORLD OF DIGGING