

Tiltrotator EC233

For 52,900–72,800 lbs excavators (24–33 metric ton)

One of the market's most powerful tiltrotators adapted for excavators up to 72,800 lbs. If EC233 is selected with engcon's standard Quick Coupler S80 and the DC2 proportional control system, EC-Oil automatic Quick Coupler system is offered as a free standard.** This means that the tiltrotator and hydraulic tools can be connected & disconnected without the operator needing to leave the cab.

Comes with hose, quick couplings and electrical installation kit for one machine.

Features:

- » The EC-Oil automatic Quick Coupler system connects the tiltrotator & hydraulic tools without the operator needing to leave the cab**
- » Q-Safe quick coupler for maximum safety
- » Comes ready for the QSC locking system to avoid improperly connected or dropped buckets
- » Comes ready for a rotation sensor (ePS) for connection to the excavator guidance system
- » Central lubrication (a single grease point for the entire tiltrotator; can also be connected to the excavator's central lubrication system)
- » Load-holding valves on tilt cylinders for maximum safety
- » Hardened piston rods
- » Up to ± 45 -degree tilt angle for best access
- » Rotation ∞

Quick coupler: Choose from S70 or S80 as standard.

Control system: Standard equipment – DC2 proportional control system for infinitely variable control with remote support capability, track/wheel steering and boom slew. For other purposes, we can deliver custom control systems.

Electrical system: Can be adapted to 12V or 24V.

Accessory: Integrated grabber, GRD detachable grab cassette*

* Read more about GRD engcon.com

** Read more about the terms and conditions regarding EC-Oil automatic Quick Coupler system as a free standard at engcon.com



Specifications

Model	EC233
Width A (inches)*:	19.7
Width B (inches)*:	15.2
Width C (inches)*:	15.2
Total length D (inches)*:	34.6
Construction height E (inches)*:	from 26.5
Weight (lbs)*:	1,786.4
Tilt range:	2x45°
Rec. hydraulic flow DC2 & SS10 (gpm):	31.7
Rec. hydraulic flow SS9 tilt/rotation (gpm):	18.5/18.5
Max hydraulic pressure (psi):	3,600
Standard mountings:	S70, S80
Max bucket width rec. by engcon (inches):	86.6
Max torque (lbf):	250,771
Base machine weight min/max (lbs):	52,900–72,800

*Standard attachment

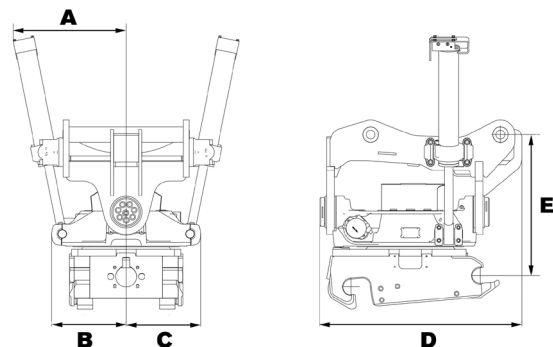

CHANGE THE WORLD OF DIGGING

engcon Canada Inc | 3220 Av. Jacques-Bureau, Laval QC H7P 0A9

E-mail canada@engcon.com | Web engcon.com