

# Tiltrotator EC219

## For 30,900–41,900 lbs excavators (14–19 metric ton)

A compact, powerful tiltrotator with low weight and height for excavators up to 41,900 lbs. If EC219 is selected with engcon's standard Quick Coupler S60 and the DC2 proportional control system, EC-Oil automatic Quick Coupler system is offered as a free standard.\*\* This means that the tiltrotator and hydraulic tools can be connected & disconnected without the operator needing to leave the cab.

Supplied complete with hoses, quick couplings and electrical equipment for one machine.

### Features:

- » The EC-Oil automatic Quick Coupler system connects the tiltrotator & hydraulic tools without the operator needing to leave the cab\*\*
- » Q-Safe quick coupler for maximum safety
- » Comes ready for detachable grabber GRD (S60)
- » Comes ready for rotating brush SWD (S60)
- » Comes ready for the QSC locking system to avoid improperly connected or dropped buckets
- » Comes ready for rotation sensor (ePS) for connection to the excavator guidance system
- » Central lubrication (a single grease point for the entire tiltrotator; can also be connected to the excavator's central lubrication system)
- » Load-holding valves on tilt cylinders for maximum safety
- » Hardened piston rods
- » Up to  $\pm 45$ -degree tilt angle for best access
- » Rotation  $\infty$

**Quick coupler:** S60 comes standard.

**Control system:** DC2 comes standard. This proportional control system provides outstanding variable control with remote support capability, track/wheel steering, and boom slew. We also offer custom control systems.

**Electrical system:** Can be adapted to 12V or 24V electrical systems.

**Accessories:** GRD detachable grabber cassette\*, SWD rotating brush\*.

\* Read more about GRD and SWD at [engcon.com](http://engcon.com)

\*\* Read more about the terms and conditions regarding EC-Oil automatic Quick Coupler system as a free standard at [engcon.com](http://engcon.com)



### Specifications

Model	EC219
Width A (inches)*:	15.6
Width B (inches)*:	12.4
Width C (inches)*:	12.2
Total length D (inches)*:	29
Construction height E (inches)*:	from 18.9
Weight (lbs)*:	983
Tilt range:	2x45°
Rec. hydraulic flow DC2 & SS10 (gpm):	31.7
Rec. hydraulic flow SS9 tilt/rotation (gpm):	17.2/18.5
Max hydraulic pressure (psi):	3,200
Standard mountings:	S60
Max bucket width rec. by engcon (inches):	66.9
Max torque (lbf):	137,187
Base machine weight min/max (lbs):	30,900–41,900

\*Standard attachment

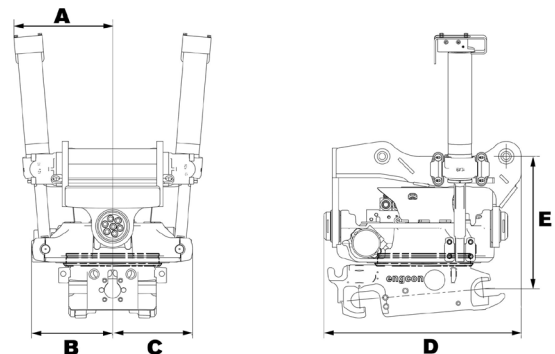

**CHANGE THE WORLD OF DIGGING**

engcon Canada Inc | 3220 Av. Jacques-Bureau, Laval QC H7P 0A9

E-mail [canada@engcon.com](mailto:canada@engcon.com) | Web [engcon.com](http://engcon.com)