

# Tiltrotator EC214

## For 19,800–30,900 lbs excavators (9–14 metric ton)

A compact, powerful tiltrotator with low weight and height for excavators up to 30,900 lbs. If EC214 is selected with engcon's standard Quick Coupler S45 or S60 and the DC2 proportional control system, EC-Oil automatic Quick Coupler system is offered as a free standard.\*\* This means that the tiltrotator and hydraulic tools can be connected & disconnected without the operator needing to leave the cab.

Supplied complete with hoses, quick couplings and electrical equipment for one machine.

### Features:

- » The EC-Oil automatic Quick Coupler system connects the tiltrotator & hydraulic tools without the operator needing to leave the cab\*\*
- » Q-Safe quick coupler for maximum safety
- » Comes ready for detachable grabber GRD
- » Comes ready for rotating brush SWD
- » Comes ready for the QSC locking system to avoid wrongly connected or dropped buckets
- » Comes ready for a rotation sensor (ePS) for connection to the excavator guidance system
- » Central lubrication (a single grease point for the entire tiltrotator; can also be connected to the excavator's central lubrication system)
- » Load-holding valves on tilt cylinders for maximum safety
- » Hardened piston rods
- » Up to  $\pm 45$ -degree tilt angle for maximum agility
- » Rotation  $\infty$

**Quick coupler:** Choose from S45 or S60 as standard.

**Control system:** DC2 proportional control system comes standard for outstanding variable control and includes remote support capability, track / wheel steering, and boom slew. Custom control systems also available.

**Electrical system:** Can be adapted to 12V or 24V electrical systems.

**Accessory:** GRD detachable grabber cassette\*, SWD rotating brush\*.

\* Read more about GRD and SWD at [engcon.com](http://engcon.com)

\*\* Read more about the terms and conditions regarding EC-Oil automatic Quick Coupler system as a free standard at [engcon.com](http://engcon.com)



### Specifications

Model	EC214
Width A (inches)*:	12.6
Width B (inches)*:	11.2
Width C (inches)*:	11.9
Total length D (inches)*:	26.2
Construction height E (inches)*:	from 18
Weight (lbs)*:	1,021
Tilt range:	2x45°
Rec. hydraulic flow DC2 & SS10 (gpm):	21.1
Rec. hydraulic flow SS9 tilt/rotation (gpm):	9.2/13.2
Max hydraulic pressure (psi):	3,200
Standard mountings:	S45, S60
Max bucket width rec. by engcon (inches):	63
Max torque (lbf):	92,933
Base machine weight min/max (lbs):	19,800–30,900

\*Standard attachment

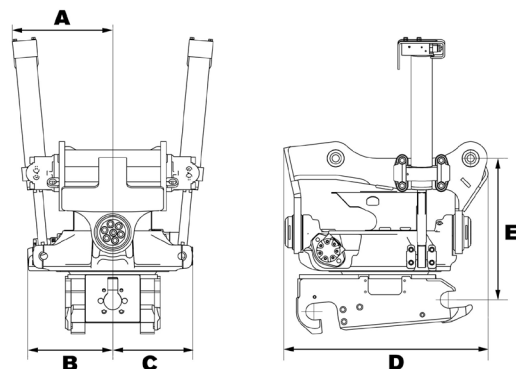

**CHANGE THE WORLD OF DIGGING**

engcon Canada Inc | 3220 Av. Jacques-Bureau, Laval QC H7P 0A9

E-mail [canada@engcon.com](mailto:canada@engcon.com) | Web [engcon.com](http://engcon.com)