

# Tiltrotator EC209

## Suitable for all excavators in the 6–9 tonne weight class

A compact, powerful tiltrotator with low weight for excavators up to 9 tons. If the EC209 is selected with engcon's standard quick hitch S45 and the proportional control system DC2, EC-Oil is offered an automatic quick hitch system as a free standard\*\* This means that the tiltrotator and hydraulic tools can be connected & disconnected without the operator needing to leave the cab.

Comes supplied with hose, quick couplings and electrical installation equipment for one machine.

### Characteristics:

- » The EC-Oil automatic quick hitch system connects the tiltrotator & hydraulic tools without the operator needing to leave the cab\*\*
- » Q-Safe quick hitch for maximum safety
- » Comes ready for detachable gripper GRD (S45)
- » Comes ready for sweeper SWD (S45)
- » Comes ready for the QSC locking system to avoid wrongly connected or dropped buckets
- » Comes ready for a rotation sensor (ePS) for connection to the excavator guidance system
- » Central lubrication (a single grease point for the entire tiltrotator; can also be connected to the excavator's central lubrication system)
- » Load-holding valves on tilt cylinders for maximum safety
- » Hardened piston rods
- » Up to  $\pm 45$ -degree tilt angle for best access
- » Rotation  $\infty$

**Quick hitch:** Standard – S45.

**Control system:** Standard – DC2. Proportional control system for infinitely variable control with remote support capability, track/wheel steering and boom slew. For other purposes, we can deliver custom control systems.

**Electrical system:** Can be adapted for 12 or 24 volt electrical systems.

**Accessory:** GRD detachable gripper cassette\*, SWD detachable sweeper\*.

\* Read more about the GRD at [engcon.com](http://engcon.com)

\*\* Read more about the terms and conditions concerning the EC-Oil automatic quick hitch system as a free standard at [engcon.com](http://engcon.com)



### Specifications

| Type  | EC209    |
|---|----------|
| Width A: (mm)*                                  | 277      |
| Width B: (mm)*                                  | 250      |
| Width C: (mm)*                                  | 273      |
| Length overall D: (mm)*                         | 561      |
| Construction height E: (mm)*                    | from 425 |
| Weight: (kg)*                                   | 287      |
| Tilt:   | 2x45°    |
| Rec. hydraulic flow DC2/SS10 (l/min):           | 60       |
| Rec. hydraulic flow SS9 tilt/rotation: (l/min): | 35/40    |
| Max hydraulic pressure: (MPa)                   | 22       |
| Standard attachments:                           | S45      |
| Max bucket width rec. by Engcon: (mm)           | 1 300    |
| Max breakout torque: (kNm)                      | 74       |
| Base machine weight: (t)                        | 6–9      |

\*Standard attachment

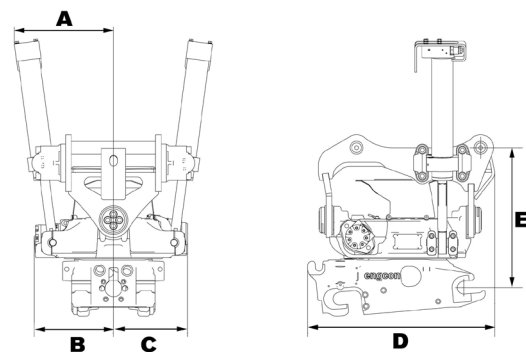

## CHANGE THE WORLD OF DIGGING